

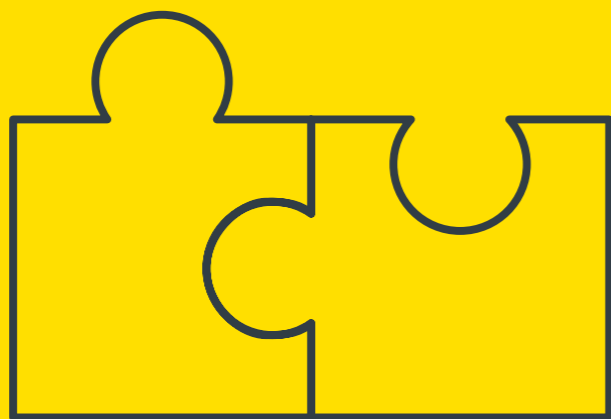

MODULAR COOKING EVO900

ZANUSSI
PROFESSIONAL

GREAT MODULARITY ACCORDING TO ZANUSSI



Evo900 is the great Zanussi Professional modular choice.
Top performance, excellent reliability and highly robust: all designed for a kitchen with considerable work loads to be performed quickly and with complete quality control.

The compositions are more or less unlimited and each one will undoubtedly meet your needs. Zanussi Professional has managed to combine tradition and innovation to achieve and allow you to achieve unbeatable results in terms of performance, sturdiness and power savings.

THE LARGE MODULES HAVE INFINITE MODULE COMBINATIONS



GAS COOKERS

2, 4, 6 or 8 burners
top or free standing



ELECTRIC COOKERS

2 or 4 square hotplates
4 square hotplates
top or free standing



INDUCTION HOBS

2 or 4 zones
2 frontal zones



INFRA-RED HOBS

2 or 4 zones



SOLD TOPS

gas versions
top or free standing



HOB COOKING TOPS



FRY TOPS

gas or electric versions



HP GRILLS

gas or electric top versions



GRILLS

gas or electric versions



BRAISING PANS

gas or electric versions



MULTI-PURPOSE COOKERS

gas or electric versions



BAIN-MARIES

electric versions



PASTA COOKERS

gas or electric versions



FRYERS

gas or electric versions



REFRIGERATED BASES



WORKTOPS AND OPEN BASES

LARGE PRODUCTIVITY OF A SOLID, COMPACT AND ERGONOMIC COOKER

PASTA COOKER

Versatile and high performing, thanks to the “**energy control**” for gas models, the infrared heating system for the electric models and the “**energy saving device**” for the refilling of the well with hot water.

EFFICIENT SAVING

Flower Flame is a system invented by Zanussi that allows the flame to be automatically regulated. It is regulated according to the size of the pot base to prevent useless and harmful heat dispersion while cooking.

GRILL HP

Highly productive and energy saving, thanks to the **large cooking surface** with easily removable grates, the “**energy control**” for a precise regulation of the power level and the piezo ignition.

AUTOMATIC FRYERS HP

Automatic cooking functions



PLUS

Range
Complete, reliable, solid and safe.

Choice
Induction, infra-red, gas and electric solutions.

Saving
Innovative devices for energy saving.

Sustainability
98% recycling of the equipment and 100% packaging.

CONVECTION OVEN

Flexible and powerful. Cooking times are reduced up to 50%, compared to a traditional static oven and can work with 2 trays simultaneously.

INDUCTION HP

Fast and efficient. The ideal solution for express service with low energy consumption thanks to the pan detection device, the energy regulator and the glass ceramic surface which only heats up upon direct contact.

FRYERS HP

Automatic cooking cycles. Automatically adjusted cooking times according to quantity of loaded product. Extend oil life significantly, thanks to advanced filtration system. Discover more on dedicated brochure 'Healthy Frying'.

CHOOSING GAS IN ALL ITS VARIATIONS

MAXIMUM LEVELS OF POWER

Maximum level power, **sturdiness**, **efficiency** and hygiene are the features that distinguish the Gas Burners in the Zanussi Professional Evo900.

- 1-piece pressed work top in stainless steel (2 mm) with smooth rounded corners.
- Exterior panels in stainless steel with Scotch-Brite finishing.
- Right-angled, laser cut side edges for flush fitting of units.

- Enameled cast iron or stainless steel pan.
- High efficiency exclusive **"flower flame"** burners.
- Burners with flame failure device
- Protected pilot light.
- 1-piece side and rear panels for durability and maximum stability **on top models**.



FLOWER FLAME IS THE POWER OF SAVING

- **Exclusive 36MJ/h "flower flame"** burner guarantees flexibility as well as high efficiency.
- Flexible burner for all your needs, thanks to its unique shape which expands both horizontally and vertically for perfect cooking with pots and pans of any shape or size.

- The **flame adapts to the diameter of the pan** bottom providing maximum coverage and reaching the cooking temperature much faster thus **reducing heat dispersion**.



GAS CONVECTION OVEN

The gas convection oven (800 mm wide) is a unique and flexible complement to the Evo900 modular cooking range.

- **Significantly reduced cooking times (up to 50%)** compared to cooking with a traditional static oven.
- Increased productivity by **cooking on 2 levels, GN 2/1**, maximizing kitchen operations.

- Increased flexibility, thanks to the possibility of working as a static oven by simply turning off the fan, thus creating the ideal conditions for obtaining the best results for all types of preparations.
- Internal cooking chamber in black enameled steel to maximize cooking efficiency.
- Operating temperature range from 120°C to 280°C.
- Piezo ignition for easy operation.



GAS STATIC OVEN

→ Maximum level performance with a power of 8,5 kW and an operating temperature from 120°C to 280°C.

- **Sturdiness** and easy cleaning guaranteed by the cooking chamber entirely in stainless steel.
- Insulation guaranteed by the 40 mm thick door.
- Supplied with stainless steel wire runners fixed to hold GN 2/1 pans.

- Oven knobs are positioned on the upper control panel for improved ergonomics.
- Uniform cooking guaranteed by the cast iron ribbed base plate (5 mm thick).
- Piezo ignition for easy operation.
- Oven chamber with 3 levels to accommodate GN 2/1 trays.



FAST, FLEXIBLE COOKING



- **THE CAST IRON HOTPLATES HAVE A SAFETY THERMOSTAT**
- **CLEANING IS MADE EASIER BY THE MOULDED STEEL SURFACE**
- **STURDINESS AND SOLIDITY THANKS TO SINGLE PIECE PANELS**

If you opt for electric cooking, you will find the same durability, reliability and safety that have made Zanussi Professional the partner par excellence for good traditional cooking.

ELECTRIC COOKING STEEL AND CAST IRON FOR AN EFFICIENT SOLIDITY

SOLID AND STABLE

The Electric Hot Plates in the EV0900 are supplied with 300x300 mm cast iron hotplates. Sturdy and safe, they are distinguished by their pressed stainless steel worktop, 2 mm thick, and by their airtight connection to the structure, which allows maximum ease in cleaning.

- 1-piece pressed work top in stainless steel (2 mm) with smooth rounded corners.

- Exterior panels in stainless steel with Scotch-Brite finishing.
- Right-angled, laser cut side edges for flush fitting of units.
- Cast iron hot plates with safety thermostat, hermetically sealed to work top.
- Individually controlled hot plates, (4 kW each), with step regulation.
- 1-piece side and rear panels for durability and maximum stability **on top models.**



ELECTRIC STATIC OVEN

- Recessed, double-skinned, insulated door with pressed internal panel for air-tight closure and better hygiene.
- Oven cavity in stainless steel with ribbed base plate. (5 mm cast iron)
- Oven chamber with 3 levels to accommodate GN 2/1 trays.

- Top and bottom heating elements can work independently or simultaneously.
- Adjustable thermostat from 110°C to 285°C.

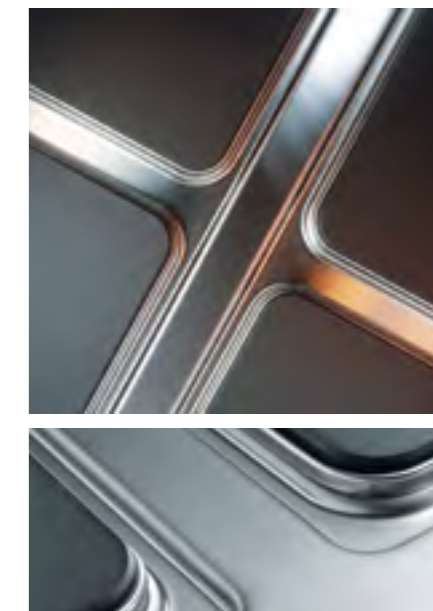

MORE POWER GREATER RELIABILITY GREATER SPEED



- **INNOVATIVE COOKING FOR THOSE WHO LOVE SPEED**
- **INDUCTION GUARANTEES POWER AND DELICACY ALL IN ONE**
- **IT IS EVEN EASIER TO CLEAN THE GLASS CERAMIC HOBS**

All types of cooking become faster, while heat dispersion is almost completely eliminated thanks to the high technology cooking surfaces.

INDUCTION HOBS. 9 COOKING LEVELS FOR COMPLETE CONTROL

HEAT LOSS IS COMPLETELY ELIMINATED

The induction cooking system, applied to the 6 mm thick ceramic glass hotplates, allows rapid and completely safe cooking without any heat dispersion.

Thanks to the power adjuster the chef has strict control over boiling. It is ideal for the preparation of **delicate dishes** such as custards and it is also perfect for pan operations.

- 1-piece pressed work top in stainless steel (2 mm) with smooth rounded corners.
- Exterior panels in stainless steel with Scotch-Brite finishing
- 1-piece side and rear panels for durability and maximum stability.
- Right-angled, laser cut side edges for flush fitting of units.
- High impact, heavy duty, 6 mm

thick Ceran® glass cooking surface with exclusive design.

- Independently controlled induction zones (diam. 280 mm - 5 kW).
- Control panel with 9 power levels and indicator light for zone operation.

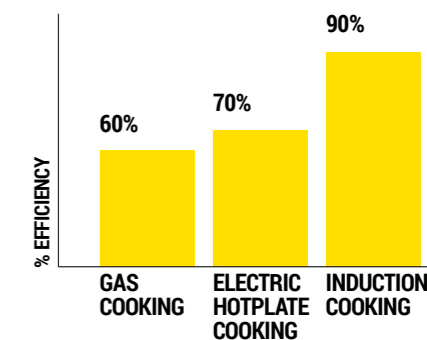

Energy efficiency, actually transferred to the food compared to the amount produced by the cooking appliances

*Electric boiling top: measured after pre-heating

SMOOTH SURFACE AND FAST MOVEMENT



- **INFRA-RED COOKING IS PERFECT FOR THOSE WHO LOVE SPEED AND POWER**
- **THE OBSTACLE-FREE HOB MAKES CLEANING EASIER**
- **THE HEAT ZONES ACTIVATE ACCORDING TO THE SIZE OF THE POT.**

Heat loss into the environment is almost non-existent and the work place is healthier.

INFRA-RED HOBS. LARGE SPACES AND COMPLETE CONTROL

POWER AND INDEPENDENT CONTROL

The Infrared Tops, consisting of radiant elements with 2 concentric circle zones with a maximum diameter of 300 mm, are controlled by an energy regulator and allow quick cooking of all foods, especially if they are initially cold. The 6 mm ceramic glass top maximises easy cleaning and pan movements.

A light indicates any overheating for **increased operator safety**.

- 1-piece pressed work top in stainless steel (2 mm) with smooth rounded corners.
- Exterior panels in stainless steel with Scotch-Brite finishing.
- 1-piece side and rear panels for durability and maximum stability.
- Right-angled, laser cut side edges for flush fitting of units.
- High impact, heavy duty, 6 mm thick Ceran® glass cooking surface with exclusive design.

- Independently controlled concentric infrared zones (diam. 300 mm - 3,4 kW max power).
- Concentric radiant elements to allow the selection of the heating area according to the pan size.
- Warning light to indicate residual heat on the surface for operator safety.



GAS SOLID TOPS AND HOB COOKING TOPS THE CONQUEST OF SPACE

A LOT OF SPACE AND HIGH TEMPERATURES

The Solid Top is provided with an extensive cast iron hotplate with a **large surface** (800x700 mm), useful for placing a lot of pans.

- 1-piece pressed work top in stainless steel (2 mm) with smooth rounded corners.
- Exterior panels in stainless steel with Scotch-Brite finishing.
- 1-piece side and rear panels for durability and maximum stability for top models.
- Right-angled, laser cut side edges for flush fitting of units.
- Durable cast iron cooking surface 30 mm thick.

- Cooking surface with **differentiated temperature zones**, maximum temperature of 500°C in center gradually decreasing to 200°C at the perimeter.
- Single central burner with optimized combustion and flame failure device.
- Piezo ignition.
- Protected pilot light.



HOB COOKING TOPS

The use of the EVO900 Hob Top allows food to be cooked or to be kept at a constant temperature before being served.

- 1-piece 2 mm pressed work top in stainless steel with smooth rounded corners.
- Exterior panels in stainless steel with Scotch-Brite finishing.
- Right-angled, laser cut side edges for flush fitting of units.

- Stainless steel burners with self-stabilizing flame. Each burner has 2 branches with 4 flame lines.
- Piezo ignition; protected pilot light (gas).
- 1-piece side and rear panels for durability and maximum stability.



FRY TOP UNIFORM HEAT AND MINIMUM HEAT LOSS

A SELECTION OF HOTPLATE FINISHINGS

The Evo900 Fry Tops have been designed to guarantee that the required temperature is reached in a short time and to ensure even heat distribution and very low heat dispersion. The **one-piece pressed cooking top with rounded corners** allows for better hygiene and is available with a smooth, ribbed or mixed surface, in either polished or brushed chrome-plated steel (only for thermostatic-controlled models).

- 1-piece pressed work top in stainless steel (2 mm) with smooth rounded corners.

- Exterior panels in stainless steel with Scotch-Brite finishing.
- 1-piece side and rear panels for durability and maximum stability for top models.
- Right-angled, laser cut side edges for flush fitting of units.
- Cooking plate (15mm thick) for even temperature distribution.
- Large drain hole with grease collection drawer.
- Large 5 litres grease collection drawer (optional) to be installed on open base.



AVAILABLE VERSIONS

Gas heating

- Thermostatic control and safety thermostat: temperature range from 90°C to 270°C.
- Piezo ignition.

Electric heating

- Incoloy armoured heating elements beneath the cooking plate.
- Thermostatic control; safety thermostat, temperature range from 120°C to 280°C.

COOKING SURFACES

Polished chrome

Polished chrome ensures maximum cleanability during the service, therefore it is easy to avoid the mixing of flavors when passing from one type of food to another.

Brushed chrome

Brushed chrome is highly resistant to scratches and ensures easy cleanability at the end of the working day.



FRY TOP^{HP}

- Highly productivity version with **non-scratch surface** thanks to the special treatment of the chromium plate.
- The 20mm thick cooking plate guarantees **outstanding temperature distribution**.

- **Large drain hole** with 60mm diameter and large capacity (3lt) grease collector.



Zanussi Professional Fry Tops fully comply with the European Food Contact Material Regulation (EC) no. 1935/2004.

GRILLS MEAT, FISH OR VEGETABLES ALWAYS PERFECT

THE CULMINATION IN TRADITIONAL COOKING

The Evo900 Grills are ideal for cooking meat, fish and vegetables.

- 1-piece pressed work top in stainless steel (2 mm) with smooth rounded corners and **pressed hygienic grease collector areas**.
- Exterior panels in stainless steel with Scotch-Brite finishing.
- Right-angled, laser cut side edges for flush fitting of units.
- **Grease collector drawer can be filled with water.**
- Removable splash-guard in stainless steel to facilitate cleaning.
- Enameled cast iron grids for easy cleaning.

- One side is dedicated to the preparation of meat with a high fat content with an angled grid with drainage channels to make the downward flow of fats easier and the other is recommended for fish, vegetables or hamburgers, which is horizontal with a more extensive expansion surface
- Grid scraper included as standard.



AVAILABLE VERSIONS

Gas grills

- Stainless steel burners with flame failure device and deflection trays to prevent blockage.

Electric grills

- Incoloy armoured heating elements beneath the cooking plate.
- Power ON indicator light.



GAS HP GRILL

This is a highly productive and energy saving grill thanks to the large **cooking surface** with easily removable grates, the "energy control" for a precise regulation of the power level and the piezo ignition.

- Highly efficient radiant heating system. (US9591947B2 and related family).
- Stainless steel burners with optimized combustion, flame failure device and protected pilot light and piezo ignition.
- Max. temperature on cooking surface 350°C.

Radiation heating system

- An efficient combustion of the burner flame guaranteed by the incoming air.
- The burner flame heats the AISI 441 radiant shield, bringing the temperature above 700°C.

- Heavy duty, removable enameled cast iron grids.
- Full depth **grease collection drawers**, 1 per burner, can be filled with water to ease cleaning and to add moisture to the food.
- Dismountable construction of the cooking top for easy cleaning, washable in dishwasher.
- Removable 3-sided splash guard in stainless steel.

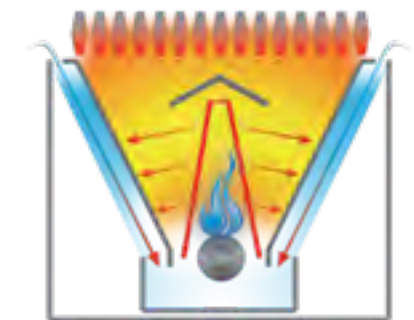

The new radiant heating system. Patented (US9591947B2 and related family)

- The heat is radiated towards the heat deflectors and onto the cooking grate.
- The cooking grate reaches an even temperature throughout, providing perfect grilling results on the entire cooking surface.

ELECTRIC HP GRILL

Now you have one more choice. The new High Performance Electric HP Grill. **Perfect performance and cooking results** even under stress.

- Cooking times are much faster and more precise. The temperature can be kept to a minimum, when not used, to achieve the ideal cooking temperature in record time.
- The heat distribution is uniform, thanks to the new heating element in contact with the grid.
- The cooking is therefore homogeneous throughout the surface.

- The cooking surface, reaching 120cm, is larger both in EVO700 and EVO900 range. In addition, you can cook more variety of food without mingling of flavors
- Cleaning is the easiest thing. The stainless steel grids can be tilted up to 90°, are fully removable and washable in the dishwasher.
- The integrated tap and drain speed up all the operations.
- The electric grid can also be used partially thanks to the separate control of the cooking zones in 80 and 120cm models.

- From heating-up to the final cleaning, the workflow is precise and meticulous. Without gaps and quick.



Patented (EP3127458B1 and related family)

FRYERS. WIDE SELECTION AND CONSTANTLY EXCELLENT PERFORMANCE

POWER AND EFFICIENCY

The Evo900 Fryers are distinguished by their excellent performance and remarkable efficiency.

- 1-piece pressed work top in stainless steel (2 mm) with smooth rounded corners.
- Exterior panels in stainless steel with Scotch-Brite finishing.

- Right-angled, laser cut side edges for flush fitting of units.
- Oil drainage tap.
- Thermostatic temperature control with safety thermostat to protect against overheating.



AVAILABLE VERSIONS

V-shaped well gas fryers

- V-shaped well with external high efficiency stainless steel burners with optimized combustion, flame failure device, protected pilot light and piezo ignition.
- up to 18 lt: from 105°C to 185°C.
- 23 lt: from 120°C to 190°C.

Gas Tube Fryer

- 23 lt ideal for floured foods and pastry.
- Gas tubes inside the well create a "cold zone" to capture food particles.
- Stainless steel burners with optimized combustion, flame failure device and protected pilot light.
- Thermostatic temperature control from 110°C to 190°C.
- Safety thermostat to protect against overheating.
- Piezo ignition.

Electric fryers

- 15 lt V-shaped well with external high efficiency infrared heating elements: from 105°C to 185°C.
- 18 lt fryer with tilting incoloy heating elements: from 105°C to 185°C.
- 23 lt V-shaped well with external high-efficiency infrared heating elements: from 110°C to 185°C.
- Selection of accessories for more efficient oil management and savings.



AUTOMATIC FRYER

V-shaped 23 lt well with external gas or electric heating elements offers power, efficiency and has the ability to bring the oil to frying temperature rapidly.

- **Electronic control** to set cooking temperature, set cooking time, main switch, set actual temperature, store cooking program.
- Electronic fryers allow constant oil temperature monitoring for easy and safe operations.
- Automatic fryers automatically adjust cooking time according to the quantity of product loaded thanks to the automatic load compensation function. Applied for Patent (EP15178651.4 and related family).
- Automatic basket lifting system ensures the cooking cycle terminates when necessary.
- The stainless steel deflectors prevent burning of food particles, which remain on the sides of the well. Ideal for breaded and floured products.

→ Sustainable operation with reduced oil consumption is possible due to specially designed accessories and advanced filtering system.

- All models with built-in oil recirculation pump are predisposed for advanced oil filtration system to remove the smallest food residuals and extend the oil life.
- High productivity is guaranteed by the high efficient heating system and the useful capacity of the basket which ensure high output of any kind of product.
- All models feature a robust construction in stainless steel for heavy duty operations.



ELECTRIC CHIP SCUTTLE

The Chip Scuttle, which is indispensable for salting and keeping all fried foods at a constant temperature after cooking, has a 316 AISI stainless steel well.

- 1-piece pressed work top in stainless steel (2 mm) with smooth rounded corners.
- Exterior panels in stainless steel with Scotch-Brite finishing.
- 1-piece side and rear panels for durability and maximum stability.

- Right-angled, laser cut side edges for flush fitting of units.
- Perforated false bottom to drain excess oil into the well basin.
- Infrared heating lamp positioned on the back of the unit.
- On/off switch.
- Suitable for GN 1/1 containers, max. height 150 mm.



PASTA COOKERS

HIGH PRODUCTIVITY AND GUARANTEED SAVING

VERY HIGH PRODUCTIVITY

The Pasta Cookers in the Evo900 guarantee **high productivity** and remarkable thermal performance. Versatile and high performing thanks to the **"energy control"** for the gas models, the **infrared heating system** for the electric models.

The **"energy saving device"**, optional for all models, allows the refilling of the well, done with hot water so boiling is constant, providing the best cooking results, increasing **productivity** and **saving energy**. No further energy supplied is needed.

- 1-piece pressed work top in stainless steel (2 mm) with smooth rounded corners.
- Exterior panels in stainless steel with Scotch-Brite finishing.

- Right-angled, laser cut side edges for flush fitting.
- GN 1/1 boiling **wells in 316L AISI** stainless steel with seamless welding.
- Electromechanical sensor prevents operation without water.
- Self-skimming system with continuous water filling regulated through manual water tap.
- Large drain with manual ball-valve for fast emptying of the well.
- **Automatic basket lifting system** (optional).

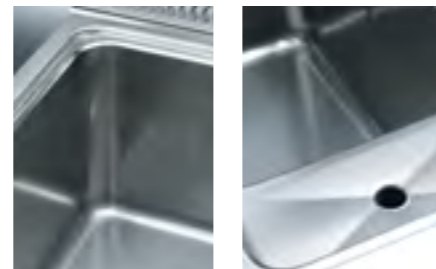

AVAILABLE VERSIONS

Gas models

- **"Energy control"** for precise power regulation, allows adapting consumptions to real needs.
- Individually controlled high efficiency burners (one for each well), with flame failure device.
- Pilot light and piezo ignition.
- No electrical connection required.

Electric models

- **Infrared heating system** positioned below the base of the well.
- 4 boiling levels to ease the use and optimise consumption.



AUTOMATIC AND PROGRAMMABLE LIFTING BASKETS SYSTEM

Programmable and automatic lifting system guarantees the repeatability of the cooking cycle, ensuring the same high quality of the food time after time due to the automation of the entire cooking process.

- Possibility to **memorize 9 cooking times** via digital control. Each lifter can work **independently** from the others.
- Easy operation, basket lifting is activated through a simple push button function.
- Can be activated manually if necessary.

- 200 mm wide, with 3 stainless steel basket supports, each able to hold GN 1/3 baskets.
- Place on either side of the pasta cooker for maximum flexibility or on both sides to provide lifting for up to 6 single portion square baskets.



BRAISING PANS SELECTION OF COOKING BASES

EMPTYING MADE EASIER

All Evo900 Braising Pan models have stainless steel wells that are shaped with rounded corners and with a pressed drainage pouring lip to make both the removal of food and cleaning operations easier.

- Well with rounded corners and **seamless welding**
- Double skinned lid in stainless steel
- Exterior panels in stainless steel with Scotch-Brite finishing

- Cooking surface in "**Duomat**" a combination of mixed stainless steels which improves thermal stability, especially indicated for "wet cooking" and is more resistant to corrosion
- High precision manual or automatic tilting system



AVAILABLE VERSIONS

Gas models

- Burners with optimized combustion, flame failure device and piezo ignition with electronic flame control
- **Burners built-in to the base** of the well move together during tilting
- Thermostatic temperature control from 120°C to 300°C

Electric models

- **Infrared heating elements** positioned beneath the cooking surface
- **Heating elements built-in to the base** of the well move together during tilting
- Thermostatic temperature control from 120°C to 300°C

Duomat surface

EVO900 braising pans with the innovative **Duomat** cooking surface (a combination of mixed stainless steels) is the best solution to guarantee a uniform temperature throughout the cooking area. It provides better thermal stability during dry cooking and is the best choice against corrosion for wet cooking



MULTI-PURPOSE COOKERS, PERFECT FOR THOSE WHO LOVE MAXIMUM FLEXIBILITY

4 IN 1

4 appliances in one! Can be used as a fry top, braising pan, boiling pan or bain-marie, a must for a kitchen needing maximum flexibility.

- 1-piece pressed work top in stainless steel (2 mm) with smooth rounded corners.
- Exterior panels in stainless steel with Scotch-Brite finishing.
- Right-angled, laser cut side edges for flush fitting of units.
- Stainless steel well with rounded corners, seamlessly welded to the work top.

→ Cooking surface in **compound steel** (3 mm layer of 316 AISI stainless steel bonded to a 12 mm layer of mild steel), optimal for multifunctional use.

- **Base contains guides** which can host GN containers to collect the food drained through the large drain hole.



AVAILABLE VERSIONS

Electric models

- Incoloy armoured heating elements beneath the cooking surface.
- Thermostatic control and energy regulator for precise cooking control and a reduction in the fluctuation of energy around the set temperature.
- Temperature range from 100°C to 300°C.



BAIN-MARIE NEUTRAL TOPS

BAIN-MARIE

- 1-piece pressed work top in stainless steel (2 mm) with smooth rounded corners.
 - Exterior panels in stainless steel with Scotch-Brite finishing.
 - **1-piece side and rear panels** for durability and maximum stability.
 - Right-angled, laser cut side edges for flush fitting of units.
 - Stainless steel well with rounded corners and seamless welding.
- Suitable for GN 1/1 containers, max. height 150 mm.
 - Operating temperature from 30°C to 90°C.
 - Maximum water filling level marked on side of well.
 - Manual water filling (water filling tap can be ordered as an option).



WORK TOPS

- 1-piece pressed work top in stainless steel (2 mm) with smooth rounded corners.
 - Exterior panels in stainless steel with Scotch-Brite finishing.
- **1-piece side and rear panels** for durability and maximum stability.
 - With closed front or with drawer.



NEUTRAL AND COOLING BASES

NEUTRAL BASES AND REFRIGERATED BASES

Open bases

- Exterior panels in stainless steel with Scotch-Brite finishing.
- Optional accessories:
 - doors with handles
 - drawers
 - runners for GN containers
 - heating kit

Refrigerated Base

- Temperature range from -2°C to +10°C.
- Built-in compressor unit.
- Thermostat, defrost indicator light and ON/OFF switch.
- Large stainless steel drawers on telescopic anti-tilt runners able to accept GN 1/1 containers.
- For ambient temperatures up to 43°C.



COMPLETE FOR EVERY KIND OF INSTALLATION

INSTALLATION ON FEET

- Standard solution, ideal when needing a fixed installation of appliances that can be adjusted in height.
- Provided as standard on all free standing appliances and bases.

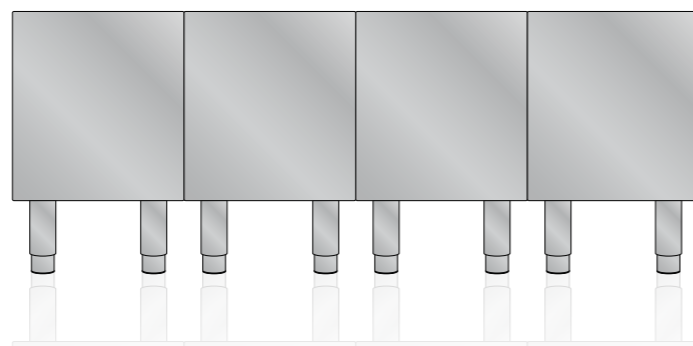

INSTALLATION ON A CEMENT PLINTH

- Provides a closed solution to be mounted on cement plinth - various solutions available.*
- Suitable for all free standing units.*

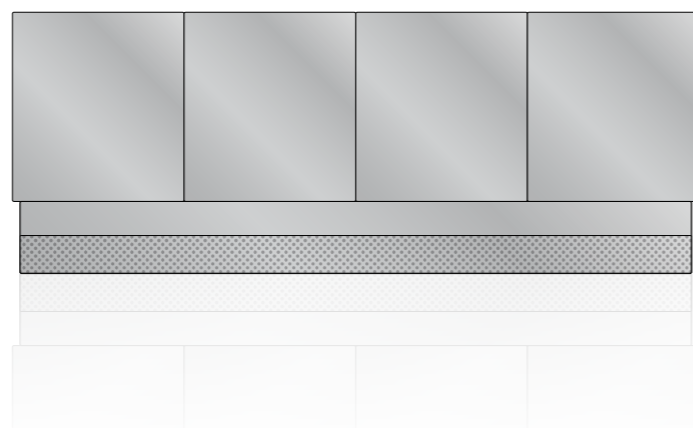

CANTILEVERED INSTALLATION

- Provides an aesthetic and hygienic solution by use of a supporting frame. Can be used for one side and back-to-back installations.
- Suitable for most units*of Evo700 and Evo900.

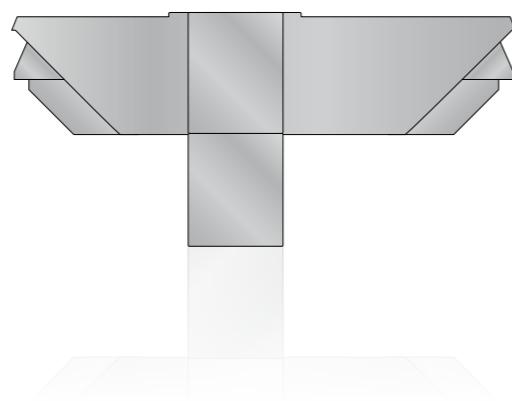

BRIDGE INSTALLATION

- Provides a hygienic solution by allowing to suspend a number of top appliances between two free standing units.
- Must be installed between two free standing units up to 1600 mm in length.*
- Free standing units - can be installed up to 2000 mm in length.*

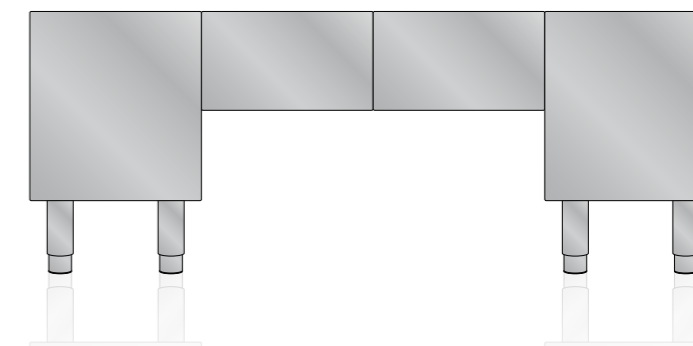

INSTALLATION WITH KICKING STRIP

- Covers the feet to close the area between the appliances and the floor.
- Can be applied to free standing appliances and bases installed on feet.

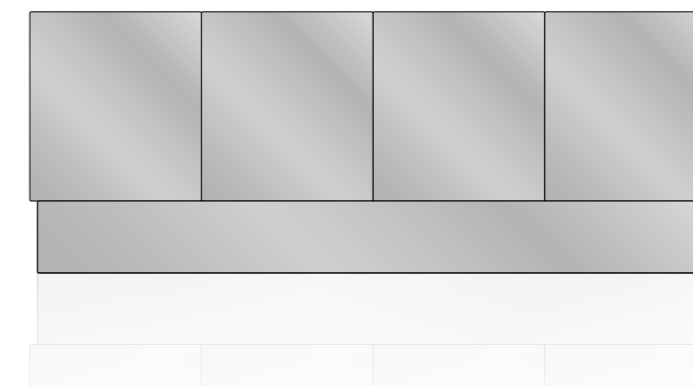

INSTALLATION ON WHEELS

- Replace feet, provides a flexible solution that allows for the easy movement of the appliances.
- Can be installed on all free standing appliances and bases.*

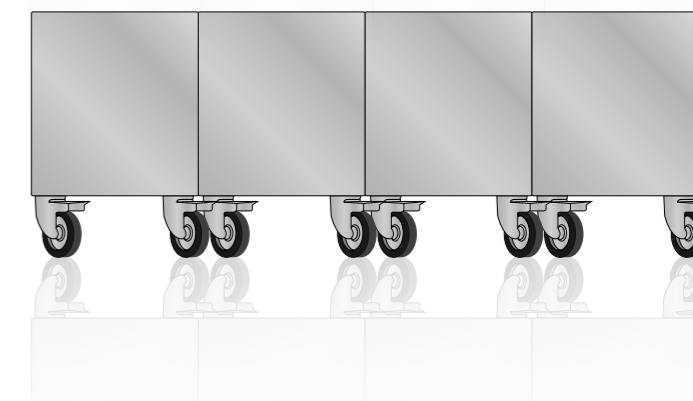

FROM A TO Z

CUSTOMER CARE PROGRAM

Always seek the advice of an expert

Listening and collaborating: these are our two watchwords. Our engineers team up with the best chefs to define the features of a product that is always reliable and easy to use.

LUUS INDUSTRIES

250 Fairbairn Road, Sunshine West
VIC Australia 3020
+61 3 9240 6822
sales@luus.com.au

ZANUSSI PROFESSIONAL

www.zanussiprofessional.com



The company reserves the right to change technical specifications without prior warning. The photographs are not contractually binding.